

| | | |
|----------------------|--------------------|-----------------|
| CAPACITY | SYMBOL/ SERIAL NO. | CIRCUIT DIAGRAM |
| AC220V~240V, 50/60Hz | | |
| 13W | | |

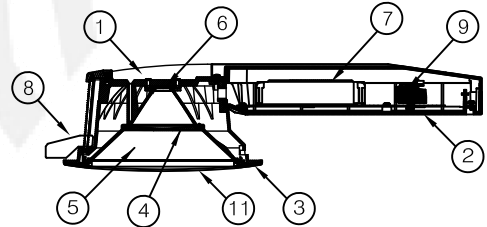

SECTION A-A

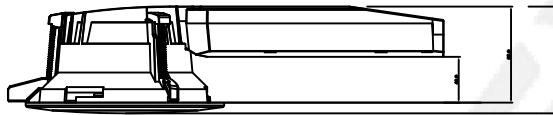
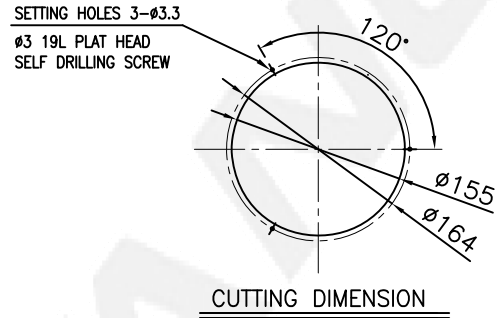
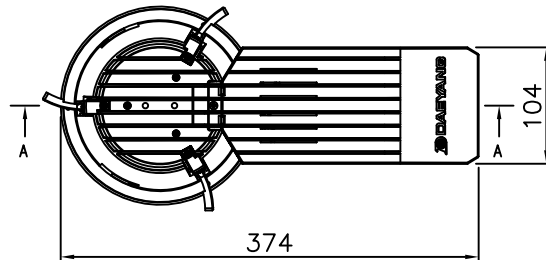
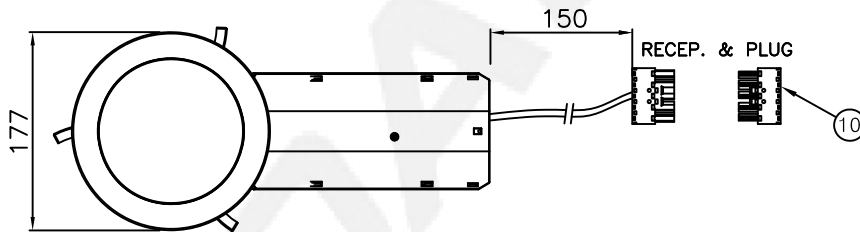

| 11 | GLOBE | POLYCARBONATE | 1 | RED | * Front part of the Down light after installation satisfies IP55 | | | | |
|-----|-----------------|-------------------|------|------------|--|---------------|-----------------------|------|---------|
| 10 | 5P CONNECTOR | RECEP. & PLUG SET | 1 | | 5 | REFLECTOR | POLYCARBONATE | 1 | |
| 9 | TERMINAL BLOCK | - | 1 | 5P | 4 | DIFFUSER | POLYCARBONATE | 1 | MILKY |
| 8 | FITTING SUPPORT | POLYCARBONATE | 3 | | 3 | FASCIA | POLYCARBONATE | 1 | WHITE |
| 7 | LED driver | - | 1 | | 2 | BODY | POLYCARBONATE | 1 | |
| 6 | LED module | - | 1 | 3,000±300K | 1 | FRONT HEAD | ALUMINIUM DIE CASTING | 1 | |
| NO. | NAME OF PARTS | MATERIAL | Q'TY | REMARKS | NO. | NAME OF PARTS | MATERIAL | Q'TY | REMARKS |

| | | | | | | | | | |
|----------|-------------|-------|-------|--|----------------------------------|-----------|--------|--|--|
| APPROVED | J. W. PARK | UNIT | MM | TITLE LED DOWN LIGHT (DALI) DIMMING CONTROL TYPE FOR MARINE USE | | | | | |
| CHECKED | S. M. SON | SCALE | N/S | | | | | | |
| DRAWING | B. K. HWANG | COLOR | N-9.3 | | | | | | |
| DATE | 2023.06.30 | IP | 55 | | | | | | |
| | | | | MODEL NO. | LEC0115WFL-P20613WGRPEDtC30-C5PW | WEIGHT | 1.1 Kg | | |
| | | | | DWG NO. | LO1710206 | SHEET NO. | 8 | | |

| NO | CONTENT | DATE | REVISER | APPROVAL |
|----|---------|------|---------|----------|
| △ | | | | |
| △ | | | | |
| △ | | | | |

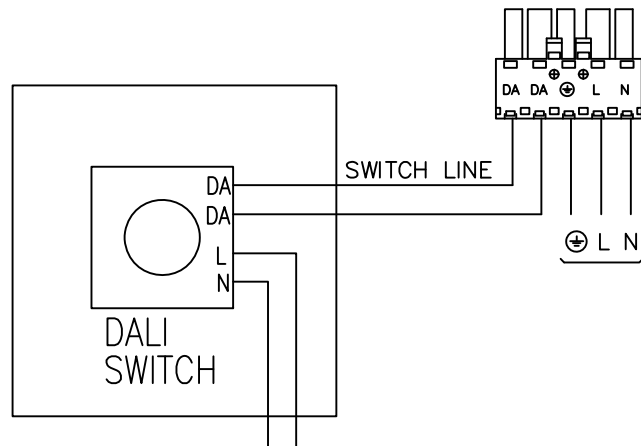
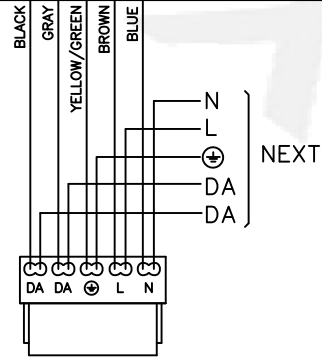
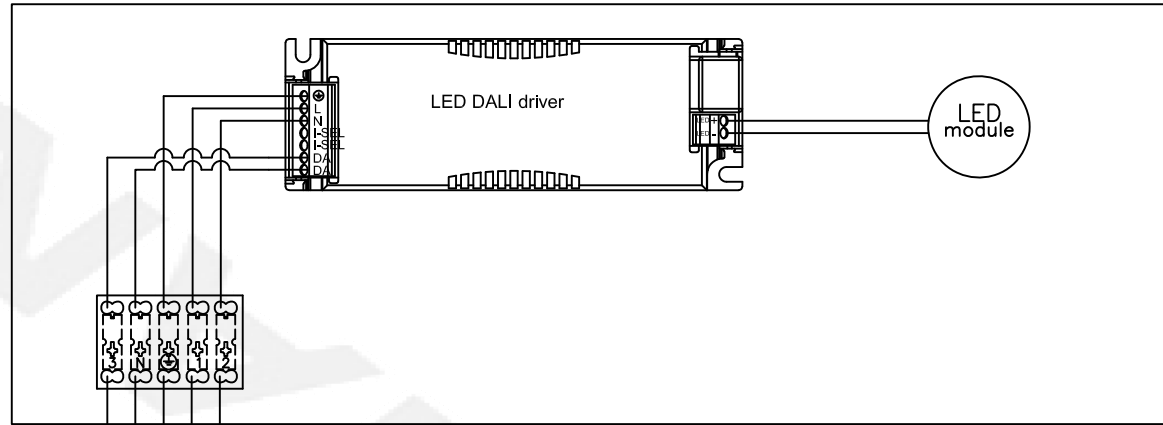

| TITLE: | SCALE | N / S | UNIT | MM | NO. | REVISED |
|---|----------------|--------------|--------|----|-----------|---------|
| DALI DIMMING TYPE CONNECTION DIAGRAM | | | | | △ | |
| | PROJECT METHOD | ⊕ | WEIGHT | KG | △ | |
| | | | | | △ | |
| | APPROVED | J. W. PARK | | | MATERIAL | ASS'Y |
| | CHECKED | S. M. SON | | | DWG NO. | |
| | DRAWN | B. K. HWANG | | | SHEET NO. | |
| | DATE | 2023. 03. 29 | | | | 3-A |